

DOCUMENT	
CONTENTS	Features
	Specifications
	Cv Tables
	Cut-Away View
	Dimensions
Close-Off Charts	
LOOKING FOR MORE	
	© 2022 Bray International, Inc. 08/12/24

GA(S) Series - Linear Valve Actuators

- Non-Spring Return - GA24-562
- Spring Return - GASRE24-450
- Spring Return - GASEX24-450

Application

The GA(S) Series is a direct mount line of linear motor actuators to be used primarily on PIC and Globe Valves. The patented drive-valve coupling allows the drive to be connected to the valve automatically as soon as the power is applied to the actuator. An external crank handle enables the desired position to be set manually as well. Microprocessor technology enables the actuator to identify the functions required and to adapt itself automatically to the control valve properties.

These actuators operate on 24V AC or DC power supply. The control signal operates on 0-10VDC, 4-20mA, On/Off (2-point), or Floating (3-point). The position feedback signal operates on 0-10VDC.

These actuators operate both 2 and 3-Way valves and are available in non-spring return and spring return versions. The GA(S) series is bi-directional, selectable via screw terminals.



Features and Benefits

- **Easy Assembly with Valve**

Stem connection takes place automatically after application of control voltage

- **Works with Bray Simple Set Max and Most Globe Valve Brands**

Multiple adaptors allow assembly on third-party valves

Spring return versions allow for fail-open or fail-closed configurations

- **Automatic Adaptation to Valve Stroke**

Built-in intelligence matches the actuator to the valve stroke.

- **Easy Configurability**

Meets the requirements of virtually any heat exchanger control application.

- **Spring Return Models**

Available "fail up/retracted" and "fail down/extended"

GA(S) Series - Technical Specifications

Technical Specifications - Actuator		
Non-Spring Return	GA24-562	On/Off, Floating and Modulating
Spring Return	GASRE24-450	On/Off, Floating and Modulating, Shaft Normally Retracted
	GASEX24-450	On/Off, Floating and Modulating, Shaft Normally Extended
Power Requirements	On/Off, Floating and Modulating	24 VAC ($\pm 20\%$) at 50/60 Hz or 24 VDC ($\pm 15\%$)
Positioner ¹	Control Signal 1	0 to 10 V, $R_i > 100 \text{ k}\Omega$
	Control Signal 2	4 to 20 mA, $R_i = 50\Omega$
	Position Feedback Signal	0 to 10 V, Load $> 10 \text{ k}\Omega$
Action	Direct or Reverse Acting	
Switching Range	300 mv	
Power Consumption ²	Non-Spring Return	10W, 18VA
	Spring Return	7.5W, 20VA
Force	Non-Spring Return	562 lbs. (2,500 N)
	Spring Return	450 lbs. (2,000 N) Power Stroke and Spring Stroke
Stroke	0" to 1.93" (0-49mm)	
Max. Temperature of Media ³	248°F (120°C)	
Ambient Conditions	Temperature	14°F to 131°F (-10° to 55°C)
	Humidity	0 to 95% RH without condensation
	Storage Temperature	-4°F to 158°F (-20° to 70°C)
Level of Protection	IP 66. Not intended for outdoor use without additional protection.	
Enclosure	Self-extinguishing plastic	
Gear Materials	Gears & Gearbox	Steel
	Mounting Column	Stainless Steel
	Mounting Bracket	Cast Light Alloy
Electrical Connection	13 AWG (2.5 mm ²) with screw terminals. Three knock-out cable entries for M20x1.5 (2x) and M16x1.5	
Motor Run Time sec. per in. (mm)	51 (2), 102 (4), 153 (6), DIP Switch Adjustable	
Spring Run Time ⁴	15... 30 seconds	
Number of Spring Returns	$> 40,000$	
Response Time - 3-Point	200 ms	
Weights	Non-Spring Return	9.1 lbs. (4.1 kg)
	Spring Return	12.3 lbs. (5.6 kg)
Agency Certifications	CE, UL Listed - Temperature-Indicating and Regulating Equipment, XAPX, XAPX7. File E366456	
Warranty	5 Years limited from time of shipment.	

¹ Also for On/Off (2-point) or Floating (3 point) depending on the connection for 24V-

² Design the transformers for this value, otherwise functional faults may occur.

³ An intermediate piece is required for media temperatures between 248°F (120°C) and 464°F (240°C)

⁴ The return time corresponds to a stroke of 0.55 in. (14 mm) to 1.58 in. (40 mm) and does not depend on the set run time.

Disclaimer - The performance specifications are nominal and conform to acceptable industry standards.

For application at conditions beyond these specifications consult the local Bray office.

Bray, Inc. shall not be liable for damages resulting from misapplication or misuse of its products.

GA(S) Series - Stroke Times

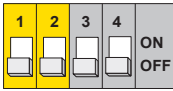
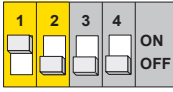
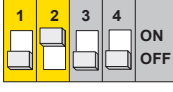

SSM Valve Stroke Times GA(S) Total Stroke = 1.93" (49mm)

Valve Stroke		Non-Spring Return or Spring Return		GA & GAS	GA & GAS	GA & GAS	GA Only
		Switch Coding	Size	2.5" & 3" .79" (20mm)	4" & 5" 1.58" (40mm)	6" & 8" 1.69" (43mm)	10" & 12" 1.89" (48mm)
GA(S) Stroke Time	51 s/in. (2s/mm)		Default Setting for Simple Set Max 2-1/2 thru 8"	40 Sec.	80 Sec.	86 Sec.	96 Sec.
	102 s/in. (4s/mm)		Optional Setting	80 Sec.	160 Sec.	172 Sec.	192 Sec.
	153 s/in. (6s/mm)		Default Setting for 10" and 12"	120 Sec.	240 Sec.	258 Sec.	288 Sec.

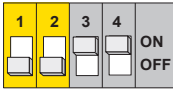
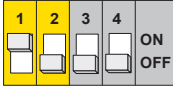
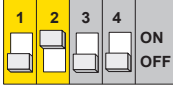
DG Valve Stroke Times GA(S) Total Stroke = 1.93" (49mm)

Valve Stroke		Non-Spring Return or Spring Return		GA & GAS	GA & GAS
		Switch Coding	Size	2.5" & 3" .75" (19mm)	4" & 6" 1.5" (38mm)
GA(S) Stroke Time	51 s/in. (2s/mm)		Default Setting for Globe Valves	38 Sec.	76 Sec.
	102 s/in. (4s/mm)		Optional Setting	76 Sec.	152 Sec.
	153 s/in. (6s/mm)		Optional Setting	114 Sec.	228 Sec.

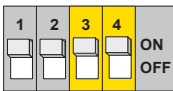
Stand Alone Actuator Stroke Times GA(S) Total Stroke = 1.93" (49mm)

Valve Stroke		Non-Spring Return or Spring Return	
		Switch Coding	
GA(S) Stroke Time	153 s/in. (6s/mm)		 = Default Setting for Stand Alone GA Actuator

GA(S) Series - Curve Characteristic Switch Settings

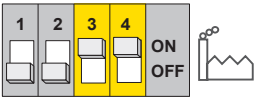
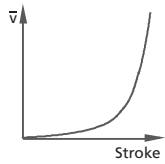
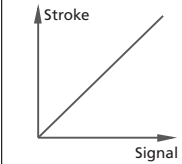
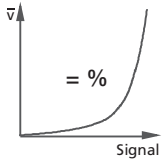
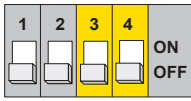
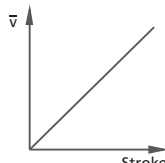
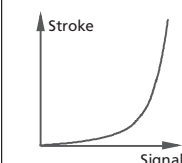
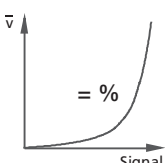
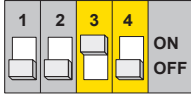
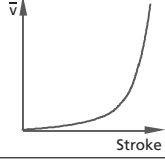
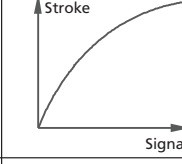
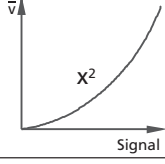
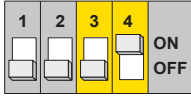
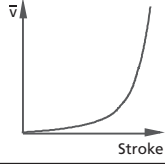
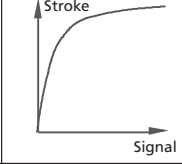
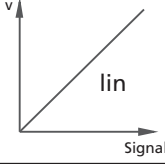
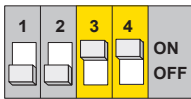
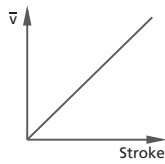
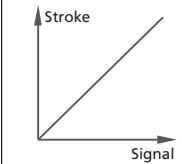
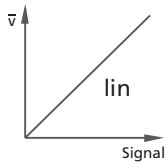
Desired Characteristic Curve	Switch Coding	Characteristic Curve for Valve	Characteristic Curve for Drive	Effective on Valve
Equal Percentage	 <p>Default setting for Globe Valves</p>			
Equal Percentage	 <p>Default setting for Simple Set Max</p>			
Quadratic	 <p>Optional setting</p>			
Linear	 <p>Optional setting</p>			
Linear	 <p>Optional setting</p>			

 = Stand Alone GA Actuator Default Setting

Model Number Selection Chart

Model Number	Force in. lbs.	Voltage	Control Signal	Auxiliary Switches	Heater
GA24-562	562	24 VAC	On/Off Floating Modulating	-A	-HT
GASRE24-450	450				
GASEX24-450					

GA(S) Series - LED Display



LED Display - The display consists of two dual-color LEDs (red/green).

Both LEDs flashing red	Calibration procedure
Upper LED lit red	Upper limit stop or shaft is fully retracted
Lower LED lit red	Lower limit stop or shaft is fully extended
Upper LED flashing green	Drive running, moving towards shaft retracted
Upper LED lit green	Drive stationary, last direction of running was shaft was retracting
Lower LED flashing green	Drive running, moving towards shaft extended
Lower LED lit green	Drive stationary, last direction of running shaft extending
Both LEDs lit green	Waiting time after switching on or after Spring Return-Spring Return Only
No LED lit	No power supply (GAS Spring Return models, terminal 21 (GA Non-Spring return models, terminals 2a or 2b)
Both LEDs are flashing red and green	Drive is in manual mode

Convenience Features

This Bray series of actuators is the most convenient retrofit actuator you can buy. This actuator calibrates itself automatically. As soon as voltage is applied to the drive for the first time, it moves to the lower limit stop on the valve, thus enabling automatic connection with the valve stem. Then it moves to the upper limit stop and the value is recorded and saved with the help of a path measurement system. The control signal and feedback signal are adjusted to this effective stroke. There is no re-calibration if the voltage is interrupted or the voltage supply is removed. The values remain saved.

The patented drive-valve coupling automatically attaches to valve spindle and easily detaches when you simply grasp the coupling and push up. There are adapters available for assembly to most globe valve manufacturers.

Furthermore, these actuators can be replaced while keeping the valve in-line for non-spring return and spring return version for both fail open and failed closed configurations.

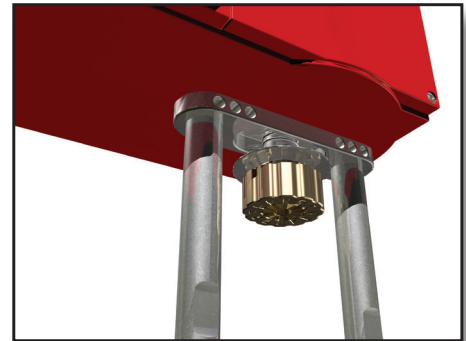

GA(S) Series - Dimensions

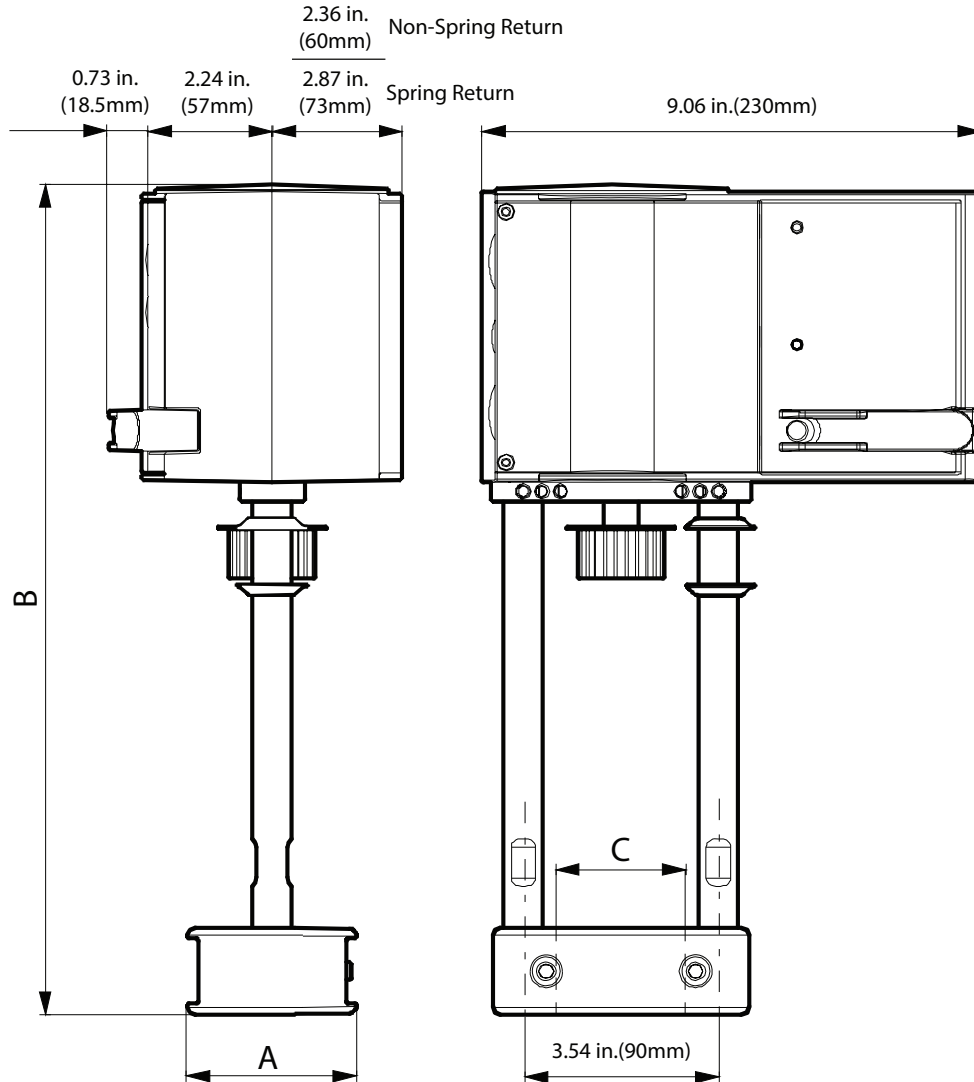

Description	A	B	C
GA(S) Series	2.52 in. (64mm)	11.38 in. (289mm)	1.73 in. (44mm)

Adaptor for media temperatures between
266°F (130°C) and 464°F (240°C)

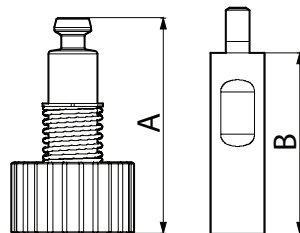

Part Number	A	B
0372336 240	4.31 in. (109.4mm)	3.94 in. (100mm)

Non-Spring Return

Modulating

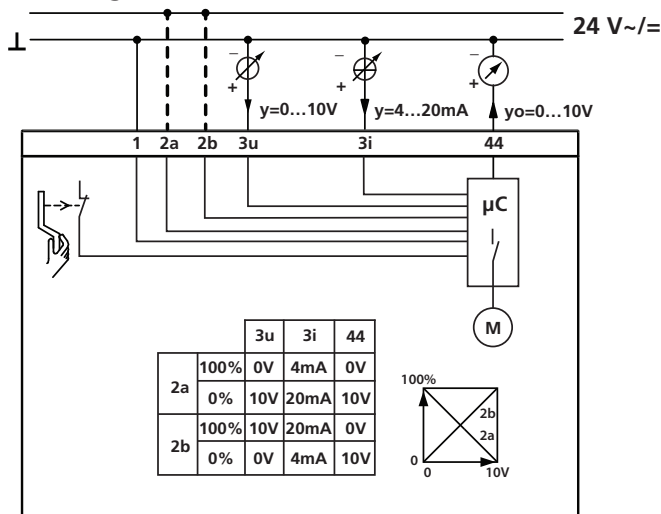

On/Off (2 Point)

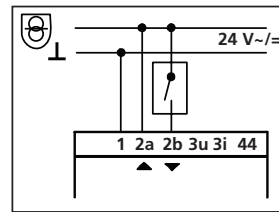

Floating (3 Point)

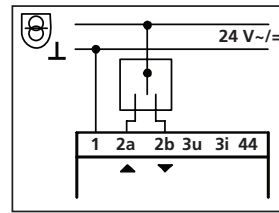

= Extra Low Voltage

Y = modulating signal

1= Neutral/Common for power and signal

2a/2b- These terminals determine forward acting/reverse acting. Only one should be powered with 24V.

Reverse Acting 2a = Extends. 0 volts = 100% retracted. 10V = 0% retracted.

Forward Acting 2b = Retracts. 0 volts = 0% retracted. 10V = 100% retracted.

3u = 0 .. 10 V, in case of control by voltage

3i = 4 .. 20 mA, in case of control by current

44 = 0 .. 10 V Feedback, independent from the use of 3u or 3i

Spring Return

Modulating

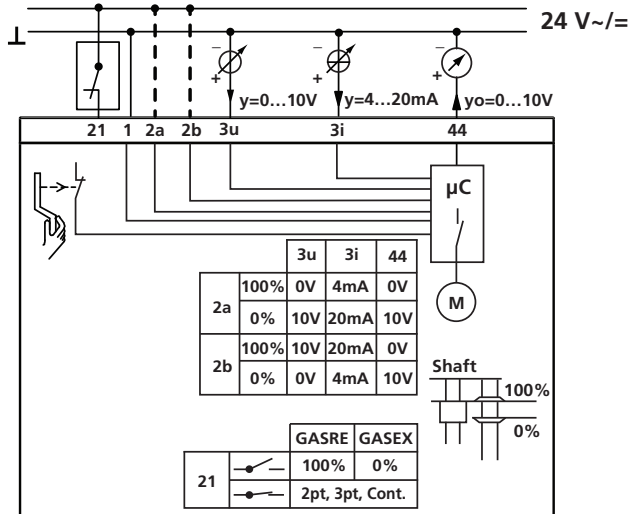

On/Off (2 Point)

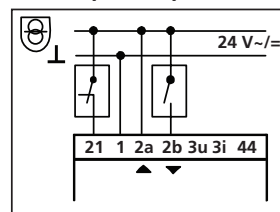

Floating (3 Point)

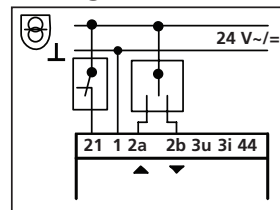

= Extra Low Voltage

Y = modulating signal

1= Neutral/Common for power and signal

2a/2b- These terminals determine forward acting/reverse acting. Only one should be powered with 24V.

Reverse Acting 2a = Extends. 0 volts = 100% retracted. 10V = 0% retracted.

Forward Acting 2b = Retracts. 0 volts = 0% retracted. 10V = 100% retracted.

3u = 0 .. 10 V, in case of control by voltage

3i = 4 .. 20 mA, in case of control by current

44 = 0 .. 10 V Feedback, independent from the use of 3u or 3i

Options

0372333 001

0372333 002

(Auxillary Switches)

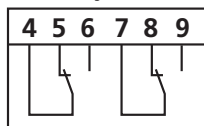

Bray COMMERCIAL

Bray Commercial provides automated Butterfly, Ball, Globe and Pressure Independent Control Valves to the commercial building HVAC market throughout the world. Wherever valve performance is required to maintain climate controlled environments, Bray can provide the required automated valves to meet the demanding flow applications of chiller/boiler isolation, air handlers and terminal units for new construction, retrofit and/or LEED certification applications in buildings.

Building Types

- Healthcare
- Data Centers
- Government and Municipal
- Sports/Entertainment/Convention Centers
- K-12 and University Education
- Transportation
- Hotels
- Office Buildings
- Retail

SINCE 1986, BRAY HAS PROVIDED FLOW CONTROL SOLUTIONS FOR A VARIETY OF INDUSTRIES AROUND THE WORLD.

VISIT BRAYCOMMERCIALDIVISION.COM TO LEARN MORE ABOUT BRAY PRODUCTS AND LOCATIONS NEAR YOU.

CORPORATE HEADQUARTERS

Bray International, Inc.
13333 Westland East Blvd.
Houston, Texas 77041
1-281-894-5454



DIVISION HEADQUARTERS

Bray Commercial
13788 West Road, Suite 200A
Houston, Texas 77041
1-888-412-Bray (2729)



All statements, technical information, and recommendations in this bulletin are for general use only. Consult Bray representatives or factory for the specific requirements and material selection for your intended application. The right to change or modify product design or product without prior notice is reserved. Patents issued and applied for worldwide. Bray® is a registered trademark of Bray International, Inc.

© 2022 BRAY INTERNATIONAL, INC. ALL RIGHTS RESERVED.